

DESPIECE



TABLA DE ESPECIFICACIONES

POSICIÓN	REFACCIÓN	ENERWELL-G1000	CÓDIGO
1.1	EMPAQUE DE MOFLE	✓	R-EWG10-EMF
1.2	VALVULA DE ADMISION	✓	R-EWG10-VADM
1.3	VALVULA DE ESCAPE	✓	R-EWG10-VESC
1.4	MOFLE	✓	R-EWG10-MFL
5.4	EMPAQUE DE CABEZA	✓	R-EWG10-EMPC
2.4	VOLTÍMETRO	✓	R-EWG10-VLT
2.12	CLAVIJA AMERICANA	✓	R-EWG10-CLAV
3.5	TAPA DE TANQUE COMBUSTIBLE	✓	R-EWG10-TAPCOM
3.6	FILTRO DE TANQUE COMBUSTIBLE	✓	R-EWG10-FLTC
5.1	MOTOR	✓	R-EWG10-MOT
5.2-5.3	ESTATOR Y ROTOR	✓	R-EWG10-ESTROT
3.4	TANQUE	✓	R-EWG10-TAN
5.7	REGULADOR AVR	✓	R-EWG10-AVR
5.8	ESCOBILLAS	✓	R-EWG10-ESCOB
6.8	SISTEMA DE ARRANQUE	✓	R-EWG10-SISAR
7.1	EMPAQUE DE CARBURADOR	✓	R-EWG10-EMPCB
7.2	EMPAQUE INSULADOR DE CARBURADOR	✓	R-EWG10-EMPIC
7.3	CARBURADOR	✓	R-EWG10-CARB
7.4	EMPAQUE DE FILTRO DE AIRE	✓	R-EWG10-EMPFA
7.5	FILTRO DE AIRE	✓	R-EWG10-FAIRE

DESPIECE

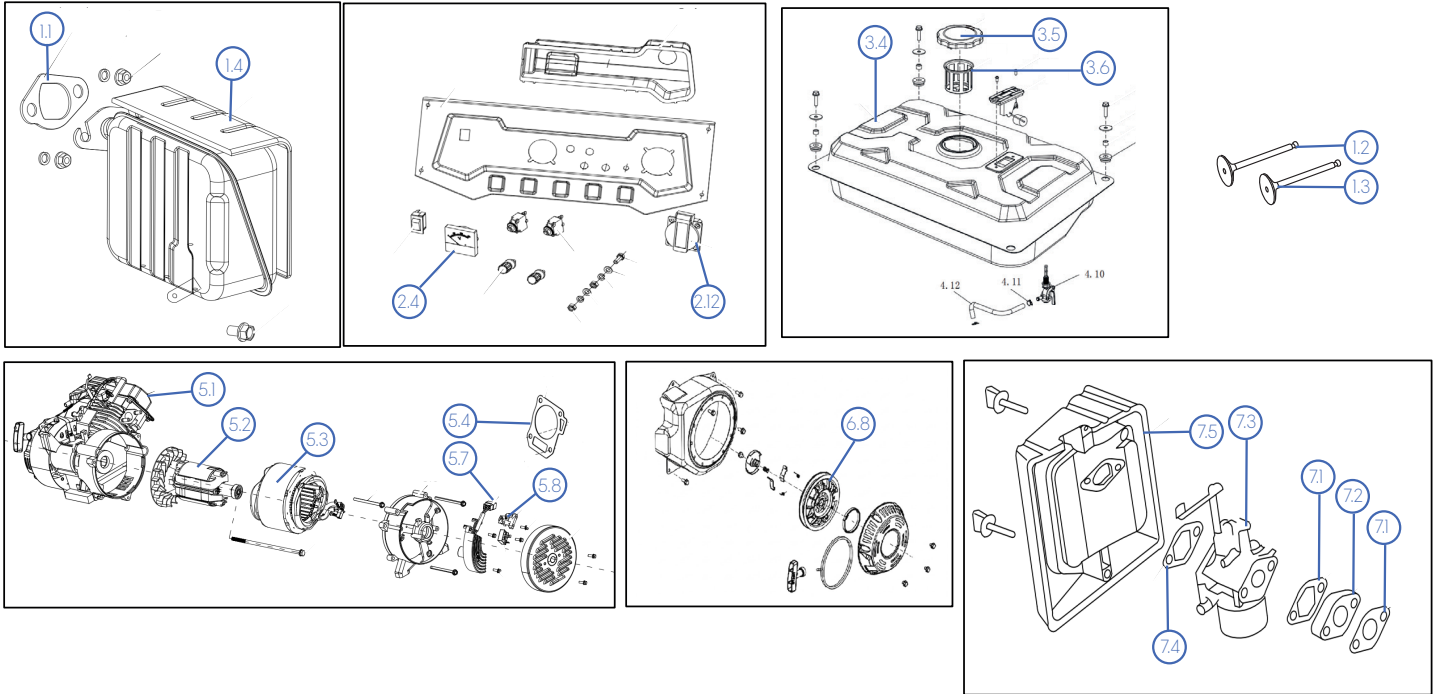

TABLA DE ESPECIFICACIONES

POSICION	REFACCIÓN	ENERWELL-G2500	MODELO
1.1	MOTOR	✓	R-EWG25-MOT
1.2	CABLE DE MOTOR TIPO 1	✓	R-EWG25-CMT1
1.3	CABLE DE MOTOR TIPO 2	✓	R-EWG25-CMT2
1.4	VALVULA DE ADMISION	✓	R-EWG25-VADM
1.5	VALVULA DE ESCAPE	✓	R-EWG25-VESC
1.10	EMPAQUE DE CABEZA	✓	R-EWG25-EMPC
2.1	EMPAQUE DE MOFLE	✓	R-EWG25-EMF
2.2	MOFLE	✓	R-EWG25-MFL
2.8	PROTECTOR BAJO NIVEL ACEITE	✓	R-EWG50/80-PBA
3.1-3.2	ESTATOR Y ROTOR 2.5KW	✓	R-EWG25-ESTROT
3.4	ESCOBILLAS	✓	R-EWG10-ESCOB
3.5	PUENTE RECTIFICADOR	✓	R-EWG181-PTRECT
3.7	REGULADOR AVR	✓	R-EWG25-AVR
3.11	CUBIERTA DE GENERADOR 2.5KW	✓	R-EWG25-CUB
4.5	TANQUE DE COMBUSTIBLE	✓	R-EWG25-TAN
5.6	VOLTÍMETRO	✓	VOLTIM-0103-001
5.7	INTERRUPTOR HIDRÁULICO	✓	R-EWG25-INT
5.9	PROTECCIÓN	✓	R-EWG10-PROT
5.10	TERMINAL	✓	R-EWG25-TERM
13.2	FILTRO DE AIRE	✓	R-EWG25-FAIRE
4.6	TAPA DE TANQUE COMBUSTIBLE	✓	R-EWG25-TAPCOM
4.7	FILTRO DE TANQUE COMBUSTIBLE	✓	R-EWG25-FLTC

DESPIECE

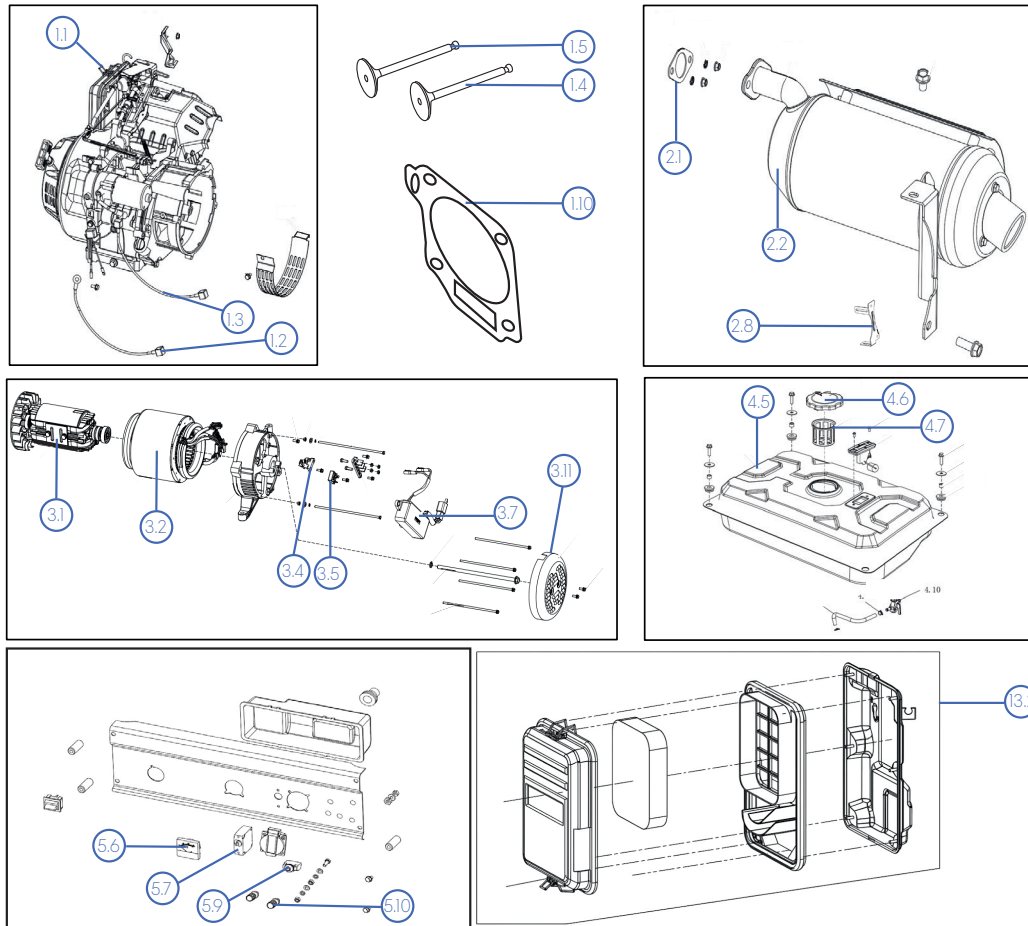
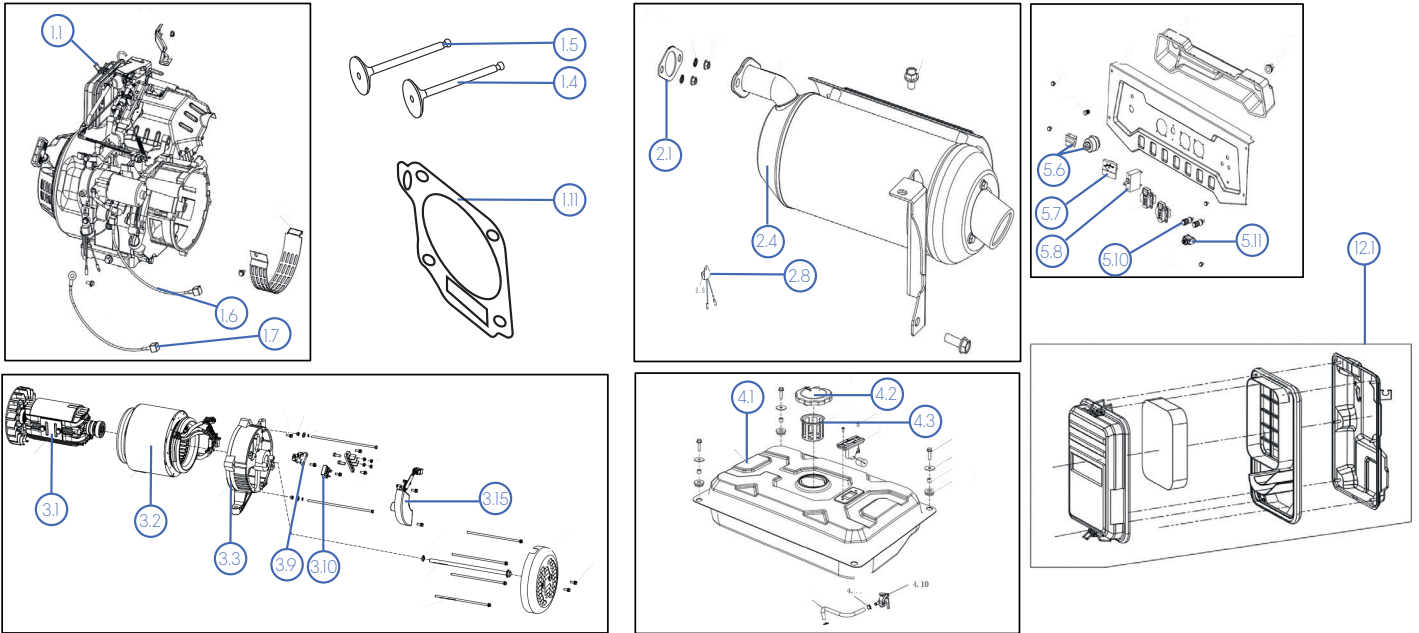

TABLA DE ESPECIFICACIONES

POSICIÓN	REFACCIÓN	ENERWELL-G5000	ENERWELL-G8000	MODELO
1.1	MOTOR	✓		R-EWG50-MOT
			✓	R-EWG80-MOT
1.6	CABLE DE MOTOR 1	✓	✓	R-EWG25-CMT1
1.7	CABLE DE MOTOR 2	✓	✓	R-EWG25-CMT2
2.1	EMPAQUE DE MOFLE	✓	✓	R-EWG50/80-EMF
2.4	MOFLE	✓		R-EWG50-MFL
			✓	R-EWG80-MFL
3.1	ROTOR	✓		R-EWG50-ROT
			✓	R-EWG80-ROT
3.10	PUENTE RECTIFICADOR	✓	✓	R-EWG18I-PTRECT
3.15	REGULADOR AVR	✓		R-EWG50-AVR
			✓	R-EWG80-AVR
3.2	ESTATOR	✓		R-EWG50-EST
			✓	R-EWG80-EST
3.3	SOPORTE PARA MOTOR	✓		R-EWG50/80-SOPM
3.9	ESCOBILLAS	✓	✓	R-EWG50/80-ESCOB
4.1	TANQUE DE COMBUSTIBLE	✓	✓	R-EWG50/80-TAN
5.6	INTERRUPTOR DE ARRANQUE	✓	✓	R-EWG50/80-INTA
5.7	VOLTIMETRO	✓	✓	R-EWG2.5/8-VLT
5.8	INTERRUPTOR 1	✓		R-EWG50-INT1
	INTERRUPTOR 2		✓	R-EWG80-INT2
5.11	PROTECCION	✓	✓	R-EWG10-PROT
5.10	TERMINALES	✓	✓	R-EWG25-TERM
1.11	EMPAQUE DE CABEZA	✓		R-EWG50-EMP
			✓	R-EWG80-EMP
1.4	VALVULA DE ADMISION	✓	✓	R-EWG50/80-VADM
1.5	VALVULA DE ESCAPE	✓	✓	R-EWG50/80-VESC
12.1	FILTRO DE AIRE	✓	✓	R-EWG50/80-FLTA
4.2	TAPA DE TANQUE	✓	✓	R-EWG50/80-TAPCOM
4.3	FILTRO DE TANQUE COMBUSTIBLE	✓	✓	R-EWG10/80-FLTC
2.8	PROTECTOR BAJO NIVEL DE ACEITE	✓	✓	R-EWG50/80-PBA